

CONTACTORS



c3controls' line of Contactors are easy to install and designed to perform in a broad range of global applications. Our Series 300 Non-Reversing and Series 310 Reversing Contactors feature DIN rail and panel mounting, IP20 guarded terminals, multi-point coils, and include a wide variety of shared accessories.



Section 4

Series 300 Non-Reversing	6
Series 310 Reversing	8
Accessories	10
Replacement Components	12
Specifications	13
Circuit Diagrams	17
Electrical Life	18
Dimensions	19

PROVEN



Conformity to Standards:

UL 508, 60947-4-1
 CSA C22.2 No. 14
 IEC 60947-1, 60947-4-1

Certifications:

UL File #: E236197 (Guide NLDX, NLDX7), E68568 (Guide NKCR, NKCR7)

CE Marked (per EU Low Voltage Directive 2006/95/EC and RoHS Directive 2011/65/EU)

Visit www.c3controls.com to download product certifications.

CONTACTORS

c3controls offers a comprehensive line of Motor Control products designed and manufactured to meet the needs of the machine builder. We promise durable products at a price that gives you an edge, and we guarantee same-day shipping. Check out all the features of our Series 300/310 standard contactors below!

DELIVERING SUPERIOR PRODUCT QUALITY AND MANUFACTURING EXCELLENCE

✓ Proven	Our Series 300 and 310 Standard Contactors are UL Listed and CE marked, meeting global standards requirements. 
✓ Compact Size	Reduced panel area for lower installed costs—Four (4) frame sizes directly interchangeable with other manufacturers.
✓ Lower Cost	Snap-on front mounted and side mounted auxiliary contacts install without the use of tools for lower installed costs.
✓ Convenient	Wide variety of AC and DC operating coils for control circuit application flexibility. 50A to 105A DC operated devices feature electronic coil control.
✓ Easy to Install	35mm DIN rail mounting for all contactors from 9A to 105A for fast and easy installation and removal, or panel mounting for more secure installation in high shock and vibration applications.
✓ Modular Design	Modular design allows easy installation of Series 320 Overload Relays and the complete range of Series 330 Motor Protection Circuit Breakers and accessories.
✓ Visible Certifications	Our product certifications and electrical ratings are clearly marked on the outside of the device for easy reference during installation.
✓ Environmentally Friendly	Environmentally friendly contacts are cadmium free and non-metallic materials are asbestos, halogen, and cadmium free. All c3controls products are compliant to the RoHS directives.
✓ Added Safety	IP20 guarded terminals with dual terminal markings prevent accidental contact with live parts.
✓ Limited Lifetime Warranty*	Every product is backed by our limited lifetime warranty—unmatched in the industry—bringing you quality components that perform in the most demanding applications.
✓ Guaranteed Same-Day Shipping*	Product availability reduces inventory, and improves cash-flow—saving you money. With c3controls any order for standard catalog items received by 6:00pm ET is guaranteed to ship same-day.
✓ Advantage Pricing	Our approach to product development, manufacturing, and focus on servicing the OEM and Electrical Equipment Builder reduces cost. The result—the best value in the industry.

*See c3controls Terms & Conditions

“When GinSan expanded to Canada, we needed to find a supplier that could provide us with motor protection products that conformed to Canadian standards without increasing our bottom line. During the evaluation and testing of a new supplier, c3controls motor control products met all of our quality standards. One added feature c3controls offers on their contactors is they have an extra, fourth contact—eliminating the need to add an extra auxiliary onto the device.”

Mike Fox, Engineering Chief • **GinSan Industries Inc.**

Non-Reversing Contactor



Reversing Contactor

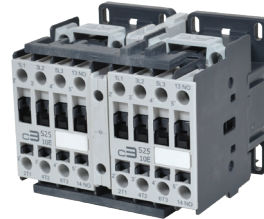

UNIQUE PRODUCT LINE FEATURES

HIGH FAULT SCCR



High fault short circuit current rating of 100kA @ 480V and 600V with Class J fuses, provides safety and reliability in high fault applications.

INTEGRAL AUXILIARY

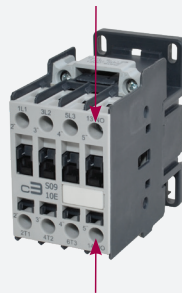

Integral auxiliary contacts, 3 power poles + 1 auxiliary, are standard on all c3controls 9A to 25A non-reversing contactors.

SEAMLESS COMPATIBILITY

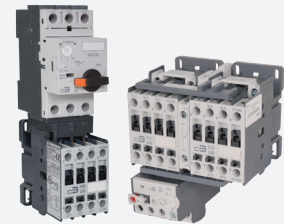

c3controls Series 310, 9A to 25A, AC/DC Reversing Contactors are compatible with directly mounted Series 320-B2 Overload Relays, and our 9A to 40A AC/DC Reversing Contactors direct mount onto Series 330 Motor Protection Circuit Breakers.

COMMON ACCESSORIES

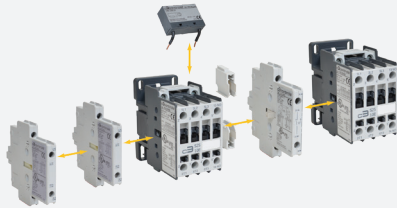

Designing starter assemblies and panels is easy! No more remembering which auxiliary works with each contactor. Our complete range of Series 300 Non-Reversing and Series 310 Reversing Contactors shares common accessories reducing inventory and simplifying installation and assembly.

MULTI-POINT TERMINAL COILS

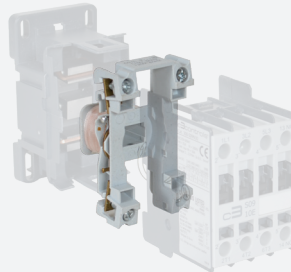

Four terminal coils on all 9A to 105A AC and DC operated contactors are easily accessible, two on the line side and two on the load side.

QUICK IDENTIFICATION

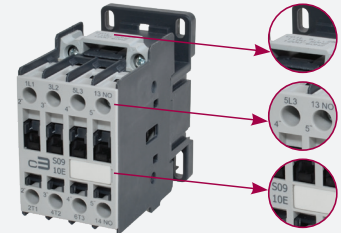

Enhanced markings, improved identification labels, and dual IEC and NEMA terminal markings ensure quick identification of product from all angles simplifying troubleshooting in panels with many devices.

FIND IT FAST

Contactors



- Certifications
- Specifications
- Dimension Drawings
- Installation Instructions
- Easy to Buy

www.c3controls.com

Motor Control Device Solutions

c3controls motor control devices are the perfect solution for manufacturers who want proper motor control and superior motor protection without having to overpay or compromise on quality. In fact, we engineer so much performance and flexibility into our products, we can deliver a remarkably better value than our competitors.

c3controls products deliver like no other.



Seamless Compatibility

Contactors, overload relays and motor protection circuit breakers are designed by c3controls to work together, with common connections and accessories, resulting in a high functioning compact starter.

LEADING THE INDUSTRY
with our compact miniature 10HP contactors and control relays. One frame size (AC or DC)—28% reduction in panel area.

Compact

The small size of c3controls motor control devices, plus features like common accessories, enable assembly into smaller control panels for lower installed costs.

Reliable Protection

Contactors provide the repeated on/off switching for the motor and are designed for motor, actuator, solenoid, and other power switching applications. Overload relays provide Trip Class 10 protection against overload and phase-loss conditions, and have ambient temperature compensation for motor protection in high temperature environments.

Ensures the protection of equipment and user.

Motor protection circuit breakers provide overload, phase-loss and short circuit protection, can be used by themselves as manual motor controllers or with contactors in group motor installations, and can achieve Type 2 coordination for optimum performance.

Type E self-protected combination manual motor controllers provide disconnecting means, branch circuit protection, motor control and motor overload protection all in a single device.



Proven

Our motor control devices are UL Listed and CE marked, meeting global standards requirements for use anywhere in the world.

NFPA 70 - National Electrical Code (NEC)

Understanding what functions are needed in your motor control circuit is critical when selecting motor control devices. Engineers benefit from the standards and codes established to ensure safety and protection to personnel and equipment.

More than just knowing the standards, c3controls, as a manufacturer of motor control products, has the application expertise you need to select the right products.

c3controls & Article 430 - Motors, Motor Circuits and Controllers			
	To Supply	NEC Part	c3controls Product Series
Motor disconnecting means		Part IX	 330 630 Type E 330 630
Motor branch-circuit, short circuit, and ground-fault protection		Part IV	 Type E 330 630
Motor circuit conductor		Part II	
Motor controller		Part VII	 300/310 330 620 630 Type E 330 630
Motor control circuits		Part VI	
Motor overload protection		Part III	 320 330 620 630 Type E 330 630
Motor		Part I	

Our motor control products align with Article 430 Part VII, Motor Controller, of the NFPA 70, the National Electrical Code.

IT'S EASY TO BUILD YOUR OWN CONTACTOR

Simply pick the code number from each of the sections below and combine them to build your part number.

Non-Reversing Contactors



Example: To build one of our most popular Contactors, the part number would be **I + II + III** or **300-S09N30D10**

I. NON-REVERSING CONTACTORS (3 NORMALLY OPEN POLES)

CODE	MAX. Ie (A)		RATINGS FOR SWITCHING AC MOTORS - AC-2, AC-3											LIST
			kW (50Hz)							HP (60Hz)				
			3 PHASE				1 PHASE		3 PHASE					
			AC-3	AC-1	230V	400/415V	500V	690V	115V	230V	200V	230V	460V	
300-S09N30	9	25	2.2	4	5.5	5.5	1/2	1-1/2	3	3	5	7-1/2	\$ 53.00	
300-S12N30	12	25	3	5.5	7.5	7.5	3/4	2	3	3	7-1/2	10	\$ 79.00	
300-S18N30	18	32	4	7.5	10	10	1	3	5	5	10	15	\$ 87.00	
300-S25N30	25	45	7.5	11	15	15	2	3	7-1/2	7-1/2	15	15	\$ 99.00	
300-S32N30	32	60	9	15	18.5	18.5	3	5	10	10	20	25	\$130.00	
300-S40N30	40	60	11	18.5	25	30	3	5	10	15	30	25	\$178.00	
300-S50N30	50	90	15	22	30	35	3	7-1/2	15	15	40	40	\$284.00	
300-S65N30	65	110	18.5	30	40	45	5	10	20	20	50	50	\$350.00	
300-S80N30	80	110	22	37	45	45	7-1/2	15	20	25	50	60	\$405.00	
300-S95N30	95	140	25	45	55	55	7-1/2	15	25	30	60	75	\$500.00	
300-S105N30	105	140	30	55	65	65	10	20	30	40	75	75	\$545.00	

II. COIL VOLTAGE CODE

AC COIL VOLTAGE CODES															
VOLTAGE	12	24	48	110 / 120	208	220	230	240	277	400	400 ~ 415	480	500	550	600
50Hz	—	—	—	D	—	—	—	—	—	—	R	—	T	U	—
60Hz	—	—	—	D	L	—	—	F	P	—	—	R	—	—	T
50/60Hz	XB	XC	XJ	—	—	XAJ	XN	—	—	XAM	—	—	—	—	—

DC COIL VOLTAGE CODES								LIST
VOLTAGE	12	24	24 ~ 28	125	110 ~ 130	208 ~ 240	250	
-S09 to -S25	ZB	ZC	—	ZQ	—	—	ZP	\$ 35.00
-S32 to -S40	ZB	ZC	—	ZQ	—	—	ZP	\$ 78.00
-S50 to -S105	—	—	EC	—	EL	EE	—	\$282.00

III. AUXILIARY CONTACT CONFIGURATION

CODE	DESCRIPTION	LIST
00	Without Auxiliary Contacts (Contactors 300-S32 to 300-S105 only)	—
10	1 Normally Open*	\$ 18.00
01	1 Normally Closed*	\$ 18.00

*NOTE: Integral right side mounted on 9A ~ 25A contactors, front mounted on 32A ~ 105A contactors.



SOME OF OUR POPULAR CONFIGURATIONS:

NON-REVERSING CONTACTORS		
CATALOG NUMBER	DESCRIPTION	LIST
300-S09N30D10	Non-Reversing, 9A, 3 Pole, 120V AC Coil, 1 NO Auxiliary Contact	\$ 71.00
300-S09N30ZC10	Non-Reversing, 9A, 3 Pole, 24V DC Coil, 1 NO Auxiliary Contact	\$106.00
300-S25N30D10	Non-Reversing, 25A, 3 Pole, 120V AC Coil, 1 NO Auxiliary Contact	\$117.00

NON-REVERSING CONTACTORS

c3controls Series 300 Contactors are ideal for motor, actuator, solenoid, and other power switching applications where panel space is at a premium and device modularity is required to satisfy virtually any application requirement. cULus and CE Markings make them suitable for use anywhere in the world. Small size, IP20 guarded terminals with dual terminal markings, and shared accessories will help reduce your total installed costs and enhance the features and performance of your equipment. Just look and see what the Series 300 has to offer.

Product features include:

- High fault short circuit rating of 100kA @ 480V and 600V with Class J fuses, provides safety and reliability in high fault applications.
- Series 300 25A contactor has an integral auxiliary, 3 power poles plus 1 auxiliary, provides more functionality in a smaller package, reducing bill of material and panel size.
- Removable and replaceable identification marker, standard on all c3controls contactors and Series 300-SFA Auxiliaries, for labeling contactors and front mounted auxiliary contacts - simplifies trouble shooting in panels with many contactors.
- Our side mounted auxiliaries and interlocks are 9mm wide and install without the use of tools onto Series 300 Contactors, reducing panel footprint and simplifying installation.
- Multi-point terminal coils on 9A to 80A AC and DC contactors providing wiring flexibility and installation convenience.
- Lower power consumption for 32A and 40A DC contactors.
- Enhanced markings and high visibility labels for ease of troubleshooting and maintenance.
- Compact size - four (4) frame sizes for devices rated from 9A to 105A. Contactors rated 15HP @ 460V (11kW @ 400V) are only 45mm (1-49/64") wide reducing panel area requirements - smaller enclosures can be used for lower installed costs.
- AC and DC operating coils for control circuit application flexibility. 50A to 105A DC operated devices feature electronic coil control.
- Environmentally friendly contacts are cadmium free and non-metallic materials are asbestos, halogen, and cadmium free.
- IP20 guarded terminals prevent accidental contact with live parts.
- Dual IEC and NEMA terminal markings for ease of wiring anywhere in the world.
- 35mm DIN rail mounting for all contactors from 9A to 105A for fast and easy installation and removal or panel mounting for more secure installation in high shock and vibration applications. Our 9A to 25A devices are easily installed or removed without the use of tools.
- Modular design allows easy installation of Series 320 Overload Relays and the complete range of Series 330 Motor Protection Circuit Breakers and accessories.
- Combination head terminal screws allow the use of straight, phillips, or posidrive screwdrivers. Allen head screws on 50A through 105A contactors make it easy to apply the proper terminal tightening torque for secure conductor connections.
- Snap-on front mounted auxiliary contacts install without the use of tools for lower installed costs. Single circuits available so you only purchase what you need.



UNIQUE PRODUCT FEATURES

MULTI-POINT TERMINAL COILS

Four terminal coils on all 9A to 105A AC and DC operated contactors are easily accessible on contactor and overload relay assemblies or contactor and motor protection circuit breaker assemblies. The control circuit can be wired from the line side or the load side of the contactor, whichever is most convenient for the installation. Control circuit wire runs can be minimized, and the devices can be easily substituted in your existing equipment without disturbing or changing your control wires. So no matter what components are being used, Series 300 Contactors can be easily and quickly wired, reducing your labor and installation costs.

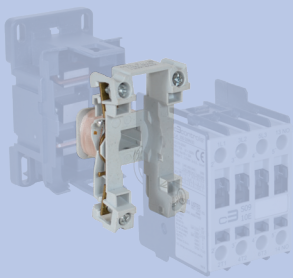

IT'S EASY TO BUILD YOUR OWN CONTACTOR

Simply pick the code number from each of the sections below and combine them to build your part number.

Reversing Contactors



Example: To build one of our most popular Contactors, the part number would be I + II + III + IV or 310-S25N30D22

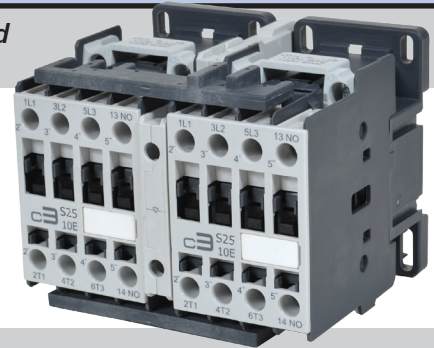

I. REVERSING CONTACTORS (3 NORMALLY OPEN POLES)

CODE	MAX. Ie (A)		RATINGS FOR SWITCHING AC MOTORS - AC-2, AC-3										LIST		
			kW (50Hz)							HP (60Hz)					
			3 PHASE				1 PHASE		3 PHASE						
			AC-3	AC-1	230V	400/415V	500V	690V	115V	230V	200V	230V		460V	575V
310-S09N30	9	25	2.2	4	5.5	5.5	1/2	1-1/2	3	3	5	7-1/2	\$ 214.00		
310-S12N30	12	25	3	5.5	7.5	7.5	3/4	2	3	3	7-1/2	10	\$ 266.00		
310-S18N30	18	32	4	7.5	10	10	1	3	5	5	10	15	\$ 282.00		
310-S25N30	25	45	7.5	11	15	15	2	3	7-1/2	7-1/2	15	15	\$ 342.00		
310-S32N30	32	60	9	15	18.5	18.5	3	5	10	10	20	25	\$ 415.00		
310-S40N30	40	60	11	18.5	25	30	3	5	10	15	30	25	\$ 511.00		
310-S50N30	50	90	15	22	30	35	3	7-1/2	15	15	40	40	\$ 769.00		
310-S65N30	65	110	18.5	30	40	45	5	10	20	20	50	50	\$ 901.00		
310-S80N30	80	110	22	37	45	45	7-1/2	15	20	25	50	60	\$1,011.00		

II. COIL VOLTAGE CODE

AC COIL VOLTAGE CODES															
VOLTAGE	12	24	48	110 / 120	208	220	230	240	277	400	400 ~ 415	480	500	550	600
50Hz	—	—	—	D	—	—	—	—	—	—	R	—	T	U	—
60Hz	—	—	—	D	L	—	—	F	P	—	—	R	—	—	T
50/60Hz	XB	XC	XJ	—	—	XAJ	XN	—	—	XAM	—	—	—	—	—

DC COIL VOLTAGE CODES								LIST
VOLTAGE	12	24	24 ~ 28	125	110 ~ 130	208 ~ 240	250	
-S09 to -S25	ZB	ZC	—	ZQ	—	—	ZP	\$ 70.00
-S32 to -S40	ZB	ZC	—	ZQ	—	—	ZP	\$ 156.00
-S50 to -S80	—	—	EC	—	EL	EE	—	\$ 564.00

III. AUXILIARY CONTACT CONFIGURATION

CODE	DESCRIPTION	LIST
00	Without Auxiliary Contacts (Contactors 310-S32 to 310-S80 only)	—
22	2 Normally Open (1 NO on Forward Contactor ^① and 1 NO on Reverse Contactor ^①) and 2 Normally Closed (1 NC on Forward Contactor ^② and 1 NC on Reverse Contactor ^②)	\$ 47.00

① Integral right side mounted on 9A ~ 25A contactors, front mounted on 32A ~ 80A contactors.
② Integrated contacts as part of the electrical/mechanical interlock.

IV. OPTIONS

CODE	DESCRIPTION	FOR CONTACTOR	LIST (deduct)
(Blank)	With Power Wires	—	—
WW	Without Interconnecting Power Wires	-S09 to -S25 -S32 to -S40 -S50 to -S80	-\$ 34.00 -\$ 51.00 -\$ 97.00



REVERSING CONTACTORS

c3controls Series 310 Reversing Contactors are ideal for reversing motors in applications where panel space is at a premium and device modularity is required to satisfy virtually any application requirement. cULus and CE Markings make them suitable for use anywhere in the world. A common mechanical interlock, power wiring modules, IP20 guarded terminals with dual terminal markings, and shared accessories help reduce your total installed costs and enhance the features and performance of your equipment. Just look and see what our Series 310 has to offer.

Product features include:

- High fault short circuit rating of 100kA @ 480V and 600V with Class J fuses, provides safety and reliability in high fault applications.
- Series 300 25A contactor has an integral - auxiliary, 3 power poles plus 1 auxiliary, provides more functionality in a smaller package, reducing bill of material and panel size.
- Modular design allows Series 320-B2 Overload Relays to be directly mounted onto Series 310, 9A to 25A, reversing contactors resulting in a high functioning compact starter.
- Removable and replaceable identification marker, standard on all c3controls contactors, simplifies troubleshooting in panels with many devices.
- Multi-point terminal coils on 9A to 80A AC and DC contactors providing wiring flexibility and installation convenience.
- Lower power consumption for 32A and 40A DC contactors.
- Series 330 Motor Protection Circuit Breakers direct mount onto Series 310, 9A to 40A AC and DC, reversing contactors, resulting in a high functioning compact starter.
- Modular design allows use with separately mounted overload relays, or Series 320 Overload Relays can be directly mounted on Series 310 32A to 50A reversing contactors without load-side interconnecting power wires.
- AC and DC operating coils for control circuit application flexibility. 50A to 80A DC operated devices feature electronic coil control.
- Environmentally friendly contacts are cadmium free and non-metallic materials are asbestos, halogen and cadmium free.
- IP20 guarded terminals prevent accidental contact with live parts.
- Dual IEC and NEMA terminal markings for ease of wiring anywhere in the world.
- Device identification marker for labeling contactors and front mounted auxiliary contacts simplify trouble shooting in panels without the use of tools.
- Power wiring modules provide reliable, rigid interconnections between the forward and reverse contactors.
- Combination head terminal screws allow the use of straight, phillips, or posidrive screwdrivers. Allen head screws on 50A through 80A contactors make it easy to apply the proper terminal tightening torque for secure conductor connections.
- Snap-on front mounted auxiliary contacts install without the use of tools for lower installed costs. Single circuits available so you only purchase what you need.

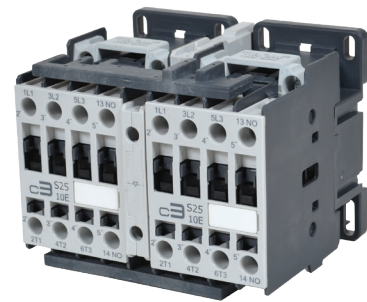

UNIQUE PRODUCT FEATURES

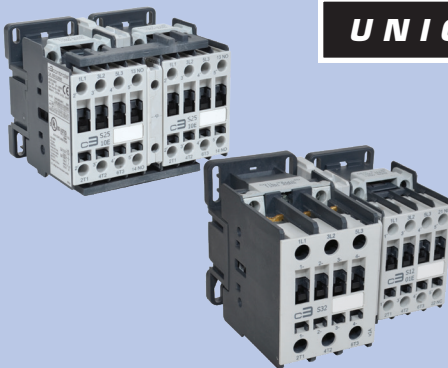

Series 310 Reversing Contactors feature a single, side mounted electrical and mechanical or mechanical only interlock that is used for the whole range of contactors, enabling a 9A contactor to be interlocked with a 105A contactor. The side mounted interlock doesn't increase the depth of the contactor and doesn't prevent front mounted auxiliary contacts from being added to either the forward or reverse contactors. Contactors are physically secured together with a dovetail bracket that installs from the bottom of the contactor - so it can't fall out when it is installed on a DIN rail or on a panel, even in high vibration applications. To complete the reversing contactor assembly, attractive, insulated wiring modules provide error free interconnections between the forward and reverse contactors. Simple to use, modular accessories make reversing contactors easy to assemble in the field - or order them factory assembled. Either way you'll get the performance and features you need for your reversing motor applications.

SOME OF OUR POPULAR CONFIGURATIONS:

REVERSING CONTACTORS		
CATALOG NUMBER	DESCRIPTION	LIST
310-S09N30D22	Reversing, 9A, 3 Pole, 120V AC Coil, 2 NO and 2 NC Auxiliary Contacts	\$261.00
310-S09N30ZC22	Reversing, 9A, 3 Pole, 24V DC Coil, 2 NO and 2 NC Auxiliary Contacts	\$331.00
310-S25N30D22	Reversing, 25A, 3 Pole, 120V AC Coil, 2 NO and 2 NC Auxiliary Contacts	\$389.00
310-S25N30ZC22	Reversing, 25A, 3 Pole, 24V DC Coil, 2 NO and 2 NC Auxiliary Contacts	\$459.00
310-S32N30D22	Reversing, 32A, 3 Pole, 120V AC Coil, 2 NO and 2 NC Auxiliary Contacts	\$462.00

FRONT MOUNTED AUXILIARY CONTACTS



Our front mounted auxiliary contacts feature IP20 guarded terminals to protect against accidental contact with live parts. The device identification marker simplifies trouble shooting in panels with many contactors. These contacts snap-on and install without the use of tools. NOTE: See chart below for maximum number of front mounted auxiliary contacts.

CODE	CONTACT CONFIGURATION	CONNECTION DIAGRAM	LIST
300-SFA10	1 Normally Open		\$11.50
300-SFA01	1 Normally Closed		\$11.50
300-SFA10EM	1 Normally Open Early Make		\$17.00
300-SFA01DB	1 Normally Closed Delayed Break		\$17.00

MAXIMUM NUMBER OF FRONT OR SIDE MOUNTED AUXILIARY CONTACTS

CONTACTOR	MAXIMUM NUMBER
S09, S12, S18, S25	4
S32, S40	6
S50, S65, S80, S95, S105	8

WIRING MODULES

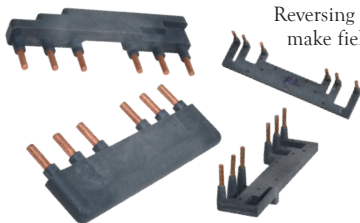

Reversing contactor power wiring modules make field assembly of reversing contactors easy. Line and load side over-molded copper bus bar conductors ensure error free installation and make for a rigid assembly with a mechanical interlock (300-SMI) or electrical/mechanical interlock (300-SMEI).

CODE	FOR USE WITH CONTACTORS	LIST
300-RWS25	S09, S12, S18, S25	\$40.00
300-RWS40	S32, S40	\$51.00
300-RWS80	S50, S65, S80	\$97.00



SIDE MOUNTED AUXILIARY CONTACTS



Side mounted auxiliary contacts feature IP20 guarded terminals to protect against accidental contact with live parts. NOTE: See chart at left for maximum number of side mounted auxiliary contacts.

CODE	CONTACT CONFIGURATION	CONNECTION DIAGRAM	LIST
300-SSA11	1 Normally Open and 1 Normally Closed		\$31.00
300-SSA20	2 Normally Open		\$31.00
300-SSA11X	1 Normally Open and 1 Normally Closed*		\$31.00
300-SSA20X	2 Normally Open*		\$31.00

*NOTE: For use with 300-SSA11 or 300-SSA20 when more than one side mounted auxiliary contact module is installed on the same side of the contactor.

INTERLOCKS



MECHANICAL INTERLOCK

Our side mounted mechanical interlock for use with reversing contactors, reversing starters, two-speed starters and star-delta (wye-delta) starters. This single interlock can be used with all size contactors from 9A ~ 105A, preventing the forward and reverse contactors from being energized at the same time.

ELECTRICAL & MECHANICAL INTERLOCK

c3controls electrical/mechanical interlock for reversing contactors has the same features as the mechanical interlock but also has two normally closed auxiliaries built into the unit for electrical interlocking, eliminating the need for two normally closed auxiliary contacts and the mechanical interlock. The result of integrating the normally closed auxiliary contact is decreased width of reversing contactors and more available auxiliary contact locations.

CODE	DESCRIPTION	LIST
300-SMI	Side Mounted Mechanical Interlock	\$34.00
300-SMEI	Side Mounted Electrical/Mechanical Interlock	\$43.00

ACCESSORIES FOR NON-REVERSING AND REVERSING CONTACTORS

The complete range of Series 300 Non-Reversing Contactors and Series 310 Reversing Contactors share common accessories including single circuit front mounted auxiliary contacts, two circuit side mounted auxiliary contacts, a single electrical/mechanical or mechanical interlock, and coil mounted surge suppressors. Designing starter assemblies and panels is easy – you don't have to remember which auxiliary is required for each contactor, they all work together. Installation is easy too – once you learn how to install each accessory, it's always the same no matter what contactor it's being installed on. If simple design and assembly isn't enough – you'll also reduce your inventory and maximize its flexibility, because unique accessories are not required for each size contactor.

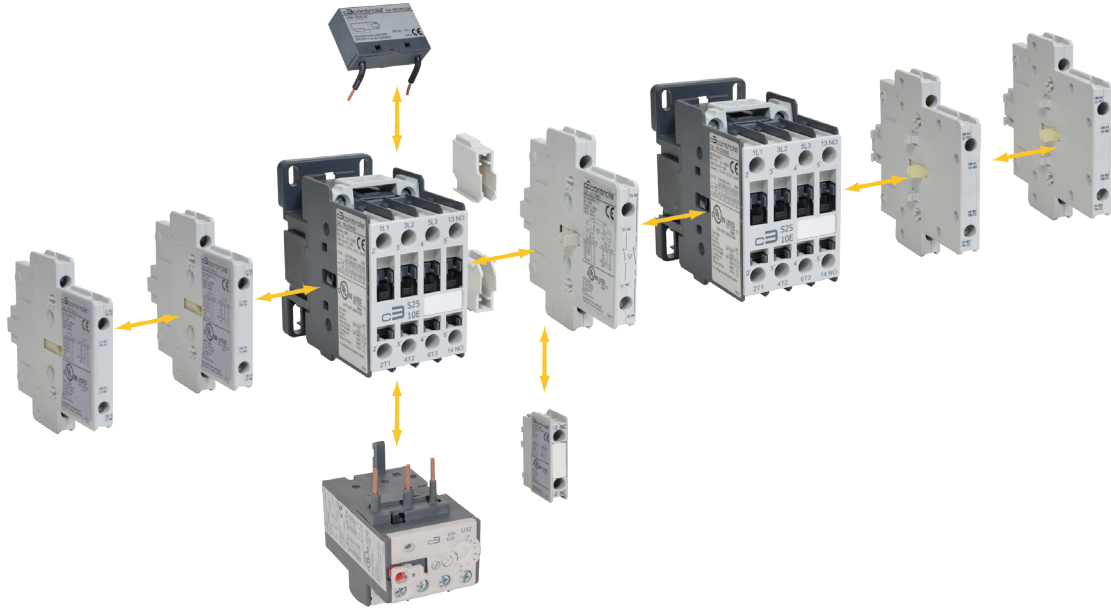

SURGE SUPPRESSORS



Coil mounted surge suppressors protect sensitive electronic components in control circuits from damaging line voltage spikes.

DISCOUNT SCHEDULE **F**

RC SURGE SUPPRESSOR			
CODE	VOLTAGE RANGE		FOR USE WITH CONTACTOR LIST
300-SRCS2J	24 ~ 48V AC		S09, S12, S18, S25, S32, S40 \$29.00
300-SRCS2AH	50 ~ 127V AC		S09, S12, S18, S25, S32, S40 \$29.00
300-SRCS2M	130 ~ 250V AC		S09, S12, S18, S25, S32, S40 \$29.00
300-SRCS5J	24 ~ 48V AC		S50, S65, S80, S95, S105 \$29.00
300-SRCS5AH	50 ~ 127V AC		S50, S65, S80, S95, S105 \$29.00
300-SRCS5M	130 ~ 250V AC		S50, S65, S80, S95, S105 \$29.00
DIODE SURGE SUPPRESSOR			
CODE	VOLTAGE RANGE		FOR USE WITH CONTACTOR LIST
300-SDS5T	12 ~ 600V DC		S09, S12, S18, S25, S32, S40, S50, S65, S80, S95, S105 \$29.00

IT'S EASY TO BUILD YOUR OWN OPERATING COIL

Simply pick the code number from each of the sections below and combine them to build your part number.

Operating Coils



Example: To build one of our most popular Operating Coils, the part number would be **I + II** or **ACS25D**

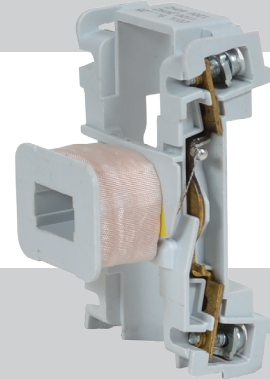

I. OPERATING COIL TYPE

CODE	DESCRIPTION	FOR USE WITH CONTACTORS	LIST
ACS25	AC Operating Coil	S09, S12, S18, S25	\$ 26.00
ACS40	AC Operating Coil	S32, S40	\$ 30.00
ACS105	AC Operating Coil	S50, S65, S80, S95, S105	\$ 42.00
DCS25	DC Operating Coil	S09, S12, S18, S25	\$ 53.00
DCS40	DC Operating Coil	S32, S40	\$141.00
DCS105	DC Operating Coil	S50, S65, S80, S95, S105	\$211.00

II. COIL VOLTAGE CODE

AC COIL VOLTAGE CODES

VOLTAGE	12	24	48	110 / 120	208	220	230	240	277	400	400 ~ 415	480	500	550	600
50Hz	—	—	—	D	—	—	—	—	—	—	R	—	T	U	—
60Hz	—	—	—	D	L	—	—	F	P	—	—	R	—	—	T
50/60Hz	XB	XC	XJ	—	—	XAJ	XN	—	—	XAM	—	—	—	—	—

DC COIL VOLTAGE CODES

VOLTAGE	12	24	24 ~ 28	125	110 ~ 130	208 ~ 240	250
-S09 to -S25	ZB	ZC	—	ZQ	—	—	ZP
-S32 to -S40	ZB	ZC	—	ZQ	—	—	ZP
-S50 to -S105	—	—	EC	—	EL	EE	—



SPECIFICATIONS:

		ELECTRICAL SPECIFICATIONS										
		S09	S12	S18	S25	S32	S40	S50	S65	S80	S95	S105
ELECTRICAL GENERAL												
	UNITS											
Rated Operating Frequency	Hz	25 ~ 400										
Impedance per Pole	mΩ	1.90	1.90	1.60	1.60	2.10	1.60	0.85	0.86	0.86	0.76	0.76
POWER DISSIPATION PER POLE												
AC-1	W	1.47	1.47	2.46	3.34	4.60	3.42	6.89	10.40	10.40	14.89	14.89
AC-3	W	0.19	0.34	0.78	1.03	1.31	1.52	2.12	3.63	5.50	6.86	8.37
Rated Coil Frequencies		AC: 50Hz, 60Hz, 50/60Hz and DC										
ELECTRICAL UL/CSA APPLICATIONS												
Rated Operating Voltage, Ue	VAC	600										
General Purpose Current Rating	A	25	25	40	40	60	60	90	110	110	140	140
RATED 1 PHASE OPERATING CURRENT, Ie												
115V	A	9.8	13.8	16	24	34	34	34	56	80	80	100
230V	A	10	12	17	28	28	28	40	40	50	60	88
RATED 1 PHASE OPERATING POWER, Pe												
115V	HP	1/2	3/4	1	2	3	3	3	5	7-1/2	7-1/2	10
230V	HP	1-1/2	2	3	3	5	5	7-1/2	10	15	15	20
RATED 3 PHASE OPERATING CURRENT, Ie												
200V	A	11	11	17.5	25.3	32.2	32.2	48.3	62.1	62.1	78.2	92
230V	A	9.6	9.6	15.2	22	28	42	42	54	68	80	104
460V	A	7.6	11	14	21	27	40	52	65	65	77	96
575V	A	9	11	17	17	27	27	41	52	62	77	77
RATED 3 PHASE OPERATING POWER, Pe												
200V	HP	3	3	5	7-1/2	10	10	15	20	20	25	30
230V	HP	3	3	5	7-1/2	10	15	15	20	25	30	40
460V	HP	5	7-1/2	10	15	20	30	40	50	50	60	75
575V	HP	7-1/2	10	15	15	25	25	40	50	60	75	75
Size		00	—	0	—	1	—	2	—	—	3	—
Standard Short Circuit Current	kA	5	5	5	5	5	5	10	10	10	10	10
Maximum Fuse Size	A	30	30	60	60	60	60	100	125	150	175	200
High Fault Short Circuit Current	kA	100	100	100	100	100	100	100	100	100	100	100
Maximum Fuse Size (Class J)	A	25	25	40	40	50	60	90	100	125	150	175
Electrical Endurance, AC-3 at Maximum Rated 3 Phase Operating Power (@460V)	Ops. (mill.)	1.8	2.0	1.6	1.6	1.5	1.5	1.6	1.8	1.5	1.5	1.0
ELECTRICAL IEC APPLICATIONS												
Rated Insulation Voltage, Ui	V	1000										
Rated Impulse Voltage Withstand, Uimp	kV	6	6	6	6	6	6	8	8	8	8	8
Rated Operating Voltage, Ue	VAC	690										
Rated Thermal Current, Ith for Ambient Temperature < 55° C (131° F)	A	25	25	32	45	60	60	90	110	110	140	140
RATED AC-1 OPERATING CURRENT, Ie												
At 55° C (131° F)	A	25	25	32	45	60	60	90	110	110	140	140
At 70° C (158° F)	A	20	20	25	32	48	48	72	88	88	110	110
RATED AC-3 OPERATING CURRENT, Ie												
220 ~ 240V	A	9	12	18	25	32	40	50	65	80	95	105
380 ~ 400V	A	9	12	18	25	32	40	50	65	80	95	105
415 ~ 440V	A	9	12	18	25	32	40	50	65	80	95	105
500V	A	7.5	10.5	14	19	24	32	38	55	63	79	85
660 ~ 690V	A	7	9	13	15	22	25	34	44	48	60	80
RATED 3 PHASE AC-3 OPERATING POWER, Pe												
220 ~ 240V	kW	2.2	3	4	6.5	9	11	15	18.5	22	25	30
380 ~ 400V	kW	4	5.5	7.5	11	15	18.5	22	30	37	45	55
415 ~ 440V	kW	4	5.5	9	12.5	15	22	30	37	45	55	55
500V	kW	5.5	7.5	10	15	18.5	25	30	40	45	55	65
660 ~ 690V	kW	5.5	7.5	10	15	18.5	30	33	45	45	55	65

ELECTRICAL AND COIL CHARACTERISTICS SPECIFICATIONS

		S09	S12	S18	S25	S32	S40	S50	S65	S80	S95	S105
ELECTRICAL IEC APPLICATIONS (CONTINUED)												
	UNITS											
RATED AC-4 OPERATING CURRENT, Ie (Achieves maximum of 200,000 operations)												
220 ~ 240V	A	7.5	10.0	15.0	20.8	26.7	33.3	41.7	54.2	66.7	79.2	87.5
380 ~ 400V	A	7.5	10.0	15.0	20.8	26.7	33.3	41.7	54.2	66.7	79.2	87.5
415 ~ 440V	A	7.5	10.0	15.0	20.8	26.7	33.3	41.7	54.2	66.7	79.2	87.5
500V	A	6.3	8.8	11.7	15.8	20.0	26.7	31.7	45.8	52.5	65.8	70.8
660 ~ 690V	A	5.8	7.6	10.8	12.5	18.3	20.8	28.3	36.7	40.0	50.0	66.7
RATED AC-4 OPERATING POWER, Pe (Achieves maximum of 200,000 operations)												
220 ~ 240V	kW	1.5	2.2	4.0	5.5	5.5	7.5	11.0	15.0	18.5	22.0	22.0
380 ~ 400V	kW	3.0	4.0	5.5	7.5	11.0	15.0	22.0	22.0	37.0	37.0	45.0
415 ~ 440V	kW	3.0	4.0	5.5	7.5	11.0	15.0	22.0	22.0	37.0	37.0	45.0
500V	kW	3.0	4.0	5.5	7.5	11.0	15.0	22.0	22.0	37.0	37.0	45.0
660 ~ 690V	kW	4.0	5.5	7.5	7.5	15.0	18.5	22.0	30.0	37.0	45.0	55.0
RATED AC-4 OPERATING CURRENT, Ie (Achieves maximum of 1,000,000 operations)												
220 ~ 240V	A	2.7	3.6	5.5	7.6	9.7	12.1	15.2	19.7	24.2	28.8	31.8
380 ~ 400V	A	2.7	3.6	5.5	7.6	9.7	12.1	15.2	19.7	24.2	28.8	31.8
415 ~ 440V	A	2.7	3.6	5.5	7.6	9.7	12.1	15.2	19.7	24.2	28.8	31.8
500V	A	2.3	3.2	4.2	5.8	7.3	9.7	11.5	16.7	19.1	23.9	25.8
660 ~ 690V	A	2.1	2.7	3.9	4.5	6.7	7.6	10.3	13.3	14.5	18.2	24.2
RATED AC-4 OPERATING POWER, Pe (Achieves maximum of 1,000,000 operations)												
220 ~ 240V	kW	0.55	0.75	1.1	1.5	2.2	3.0	4.0	4.0	5.5	7.5	7.5
380 ~ 400V	kW	1.1	1.5	2.2	3.0	4.0	5.5	5.5	7.5	11.0	11.0	15.0
415 ~ 440V	kW	1.1	1.5	2.2	3.0	4.0	5.5	5.5	7.5	11.0	11.0	15.0
500V	kW	1.1	1.5	2.2	3.0	4.0	5.5	5.5	7.5	11.0	11.0	15.0
660 ~ 690V	kW	1.5	1.5	3.0	3.0	5.5	5.5	7.5	11.0	11.0	15.0	22.0
RATED SHORT-TIME CURRENT, Icw												
1 Second	A	455	455	570	630	1010	1265	1580	2530	2530	3300	3300
5 Seconds	A	205	205	254	280	450	450	710	1130	1130	1485	1485
10 Seconds	A	144	144	180	200	320	400	500	800	800	1050	1050
30 Seconds	A	85	85	104	115	185	230	290	460	460	600	600
1 Minute	A	60	60	74	80	130	165	205	325	325	430	430
3 Minutes	A	35	35	46	50	90	100	120	185	185	250	250
Short Circuit Protection with Fuses (gG/gL) Ue ≤ 690V												
Type 1	A	50	50	63	63	100	125	200	200	200	250	250
Type 2	A	25	35	35	50	63	80	100	125	125	160	200
MAXIMUM ELECTRICAL SWITCHING RATE												
AC-1	Ops./hr.	1200	1200	1200	1200	1200	1200	1200	1200	1200	600	600
AC-3	Ops./hr.	1200	1200	1200	1200	1200	1200	1200	1200	1200	600	600
AC-4	Ops./hr.	360	360	360	360	360	200	200	200	200	200	200
Electrical Endurance, AC-3 at Maximum Rated 3 Phase Operating Power (@400V)		Ops. (mill.)	1.6	1.8	1.3	1.4	1.3	1.3	1.2	1.4	1.2	1.2
Making Capacity		A	450	450	450	450	550	550	1000	1000	1000	1280
BREAKING CAPACITY												
Ue ≤ 400V		A	250	250	250	250	450	450	920	920	920	1050
Ue = 500V		A	250	250	250	250	450	450	920	920	920	1050
Ue = 690V		A	130	130	130	130	170	205	780	780	780	950
COIL CHARACTERISTICS												
Rated Insulation Voltage, Ui		V	1000									
OPERATING LIMITS												
50HZ, 60HZ, 50/60HZ												
Operating		xUc	0.80 ~ 1.10									
Pick-Up		xUc	0.60 ~ 0.80	0.60 ~ 0.80	0.60 ~ 0.80	0.60 ~ 0.80	0.60 ~ 0.80	0.60 ~ 0.80	0.65 ~ 0.80	0.65 ~ 0.80	0.65 ~ 0.80	0.65 ~ 0.80
Drop-Out		xUc	0.35 ~ 0.55	0.35 ~ 0.55	0.35 ~ 0.55	0.35 ~ 0.55	0.40 ~ 0.60	0.40 ~ 0.60	0.40 ~ 0.60	0.40 ~ 0.60	0.40 ~ 0.60	0.40 ~ 0.60

MECHANICAL, ENVIRONMENTAL AND CONSTRUCTION SPECIFICATIONS

		S09	S12	S18	S25	S32	S40	S50	S65	S80	S95	S105
COIL CHARACTERISTICS (CONTINUED)												
	UNITS											
DC												
Operating	xUc	0.80 ~ 1.10										
Pick-Up	xUc	0.45 ~ 0.65	0.45 ~ 0.65	0.45 ~ 0.65	0.45 ~ 0.65	0.45 ~ 0.75	0.45 ~ 0.75	0.70 ~ 0.80	0.70 ~ 0.80	0.70 ~ 0.80	0.70 ~ 0.80	0.70 ~ 0.80
Drop-Out	xUc	0.15 ~ 0.30	0.15 ~ 0.30	0.15 ~ 0.30	0.15 ~ 0.30	0.15 ~ 0.30	0.15 ~ 0.30	0.40 ~ 0.60	0.40 ~ 0.60	0.40 ~ 0.60	0.40 ~ 0.60	0.40 ~ 0.60
COIL CONSUMPTION												
50HZ, 60HZ, 50/60HZ												
Pick-Up	VA	50 ~ 70	50 ~ 70	50 ~ 70	50 ~ 70	70 ~ 90	70 ~ 90	250 ~ 275	250 ~ 275	250 ~ 275	250 ~ 275	250 ~ 275
Hold-In	VA	7 ~ 11	7 ~ 11	7 ~ 11	7 ~ 11	9 ~ 13	9 ~ 13	16 ~ 20	16 ~ 20	16 ~ 20	16 ~ 20	16 ~ 20
DC												
Pick-Up	W	5 ~ 9	5 ~ 9	5 ~ 9	5 ~ 9	7 ~ 10	7 ~ 10	340	340	340	340	340
Hold-In	W	5 ~ 9	5 ~ 9	5 ~ 9	5 ~ 9	7 ~ 10	7 ~ 10	6.5	6.5	6.5	6.5	6.5
OPERATING TIMES												
AC												
Pick-Up	msec.	8 ~ 20	8 ~ 20	8 ~ 20	8 ~ 20	10 ~ 19	10 ~ 19	15 ~ 30	15 ~ 30	15 ~ 30	15 ~ 30	15 ~ 30
Drop-Out	msec.	6 ~ 13	6 ~ 13	6 ~ 13	6 ~ 13	5 ~ 25	5 ~ 25	9 ~ 15	9 ~ 15	9 ~ 15	9 ~ 15	9 ~ 15
DC												
Pick-Up	msec.	35 ~ 45	35 ~ 45	35 ~ 45	35 ~ 45	40 ~ 55	40 ~ 55	50 ~ 60	50 ~ 60	50 ~ 60	50 ~ 60	50 ~ 60
Drop-Out	msec.	7 ~ 12	7 ~ 12	7 ~ 12	7 ~ 12	30 ~ 65	30 ~ 65	55 ~ 60	55 ~ 60	55 ~ 60	55 ~ 60	55 ~ 60
POWER DISSIPATION												
50Hz, 60Hz, 50/60Hz	W	2.6	2.6	2.6	2.6	4.3	4.3	8.0	8.0	8.0	8.0	8.0
POWER FACTOR												
Closed	cos(φ)	0.33	0.33	0.33	0.33	0.28	0.28	0.26	0.26	0.26	0.26	0.26
Open	cos(φ)	0.84	0.84	0.84	0.84	0.73	0.73	0.54	0.54	0.54	0.54	0.54
MECHANICAL												
Mechanical Endurance	Ops. (mill.)	10										
Maximum Mechanical Switching Rate	Ops./hr.	9,000										
ENVIRONMENTAL												
Ambient Operating Temperature	°C / °F	-25 to +55 / -13 to +131										
Ambient Storage Temperature	°C / °F	-55 to +80 / -58 to +176										
Altitude	m / ft.	3,000 / 9,792										
CONSTRUCTION GENERAL												
Pollution Degree		3	3	3	3	3	3	3	3	3	3	3
INGRESS PROTECTION												
Main Terminals		IP20	IP20	IP20	IP20*	IP20*	IP20*	IP20*	IP20*	IP20*	IP20*	IP20*
Coil Terminals		IP20	IP20	IP20	IP20	IP20	IP20	IP20	IP20	IP20	IP20	IP20
Auxiliary Contact Terminals		IP20	IP20	IP20	IP20	IP20	IP20	IP20	IP20	IP20	IP20	IP20
Weight	kg	0.295	0.295	0.295	0.295	0.52	0.54	1.105	1.12	1.13	1.45	1.47
	lbs.	0.65	0.65	0.65	0.65	1.15	1.19	2.44	2.47	2.49	3.20	3.24

*NOTE: With conductors connected.

ROHS COMPLIANCE For RoHS compliance documentation by product, refer to www.c3controls.com.

CONSTRUCTION CONDUCTOR CROSS-SECTIONS, MAIN TERMINALS

		S09 - S25		S32 - S40		S50 - S80		S95 - S105	
	UNITS								
MAIN TERMINAL CAPACITY									
Solid Stranded and Finely Stranded without End Sleeve	mm ²	2 x 0.5 ~ 6		2 x 1 ~ 14		2 x 1 ~ 34		2 x 1 ~ 43	
AWG Wire	AWG	2 x 20 ~ 10, 1 x 20 ~ 8*		2 x 18 ~ 6		2 x 16 ~ 2		2 x 16 ~ 1	
Recommended Strip Length	mm	8.5		10		13		15	
	in	5/16		3/8		1/2		9/16	
Tightening Torque	Lb-in.	8.8 ~ 16.9		22.1 ~ 26.6		35.4 ~ 53.1		44.3 ~ 57.5	
	Nm	1.0 ~ 1.9		2.5 ~ 3.0		4.0 ~ 6.0		5.0 ~ 6.5	
Screwdriver		Phillips nr. 2		Phillips nr. 2		Allen 4mm		Allen 4mm	

AUXILIARY CONTACTS SPECIFICATIONS

		INTERNAL AUXILIARY CONTACT		CONTACT BLOCKS	
		S09-S25		300-SFA & 300-SSA	
ELECTRICAL GENERAL					
	UNITS				
Minimum Switching Capacity		5mA @ 17V			
Electrical Endurance	Ops. (mill.)	1			
Mechanical Endurance	Ops. (mill.)	15			
Non-Overlap Time	msec.	1.5			
Insulation Resistance	MΩ	>10			
ELECTRICAL UL/CSA APPLICATIONS					
Rated Operating Voltage, Ue	V	600			
PILOT DUTY RATING					
AC		A600			
DC		P600		Q600	
ELECTRICAL IEC APPLICATIONS					
Rated Insulation Voltage, Ui	V	1000			
Rated Operating Voltage, Ue	V	690			
Rated Thermal Current, Ith for Ambient Temperature <55° C	A	20		10	
RATED AC-15 OPERATING CURRENT, Ie					
110 ~ 120V	A	10		6	
220 ~ 240V	A	10		6	
380 ~ 400V	A	6		4	
415 ~ 450V	A	5		3.5	
500V	A	4		2.5	
600 ~ 690V	A	2		1.5	
RATED DC-13 OPERATING CURRENT, Ie					
24V	A	6		6	
48V	A	4		4	
110V	A	2		2	
220V	A	0.7		0.7	
440V	A	0.7		0.3	
MAKING CAPACITY, Im					
AC-15/AC-11 Ue ≤ 400V 50/60Hz	A	250		90	
DC-13/DC-11 Ue ≤ 220V	A	250		90	
BREAKING CAPACITY, Im					
AC-15/AC-11 Ue ≤ 400V 50/60Hz	A	250		60	
DC-13/DC-11 Ue ≤ 220V	A	2		0.95	
Short Circuit Protection with Fuses (gG/gL)	A	10		10	
ROHS COMPLIANCE		For RoHS compliance documentation by product, refer to www.c3controls.com .			

OPERATING POSITIONS

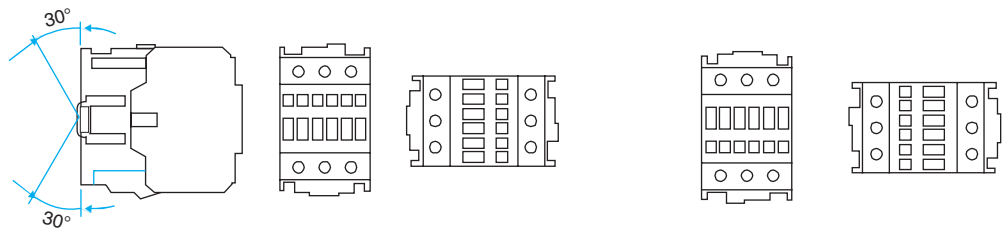

SERIES 300 NON-REVERSING CONTACTOR CIRCUIT DIAGRAMS

POWER CIRCUIT

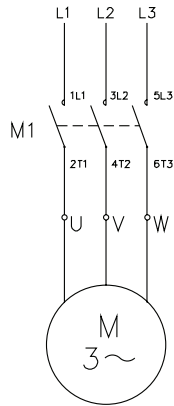

CONTROL CIRCUIT

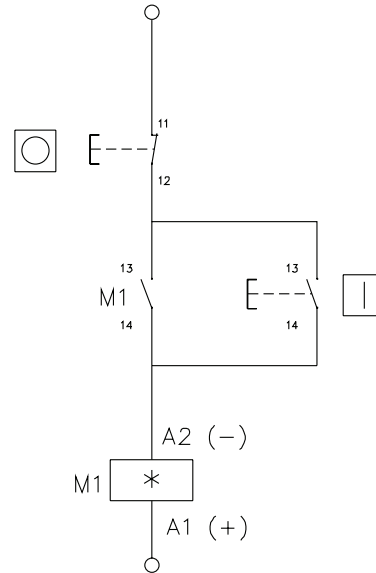

- M1 = Contactor
- I = Start Push Button
- E = Emergency Stop Push Button
- * = Coil Voltage Code

SERIES 310 REVERSING CONTACTOR CIRCUIT DIAGRAMS

POWER CIRCUIT

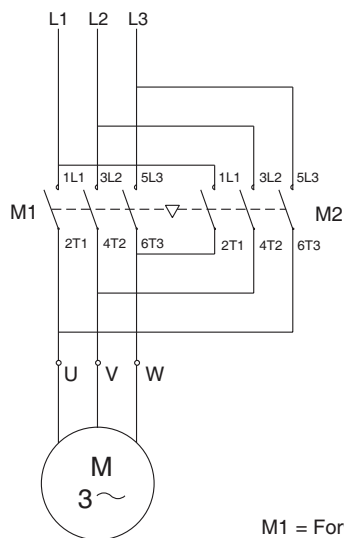

CONTROL CIRCUIT

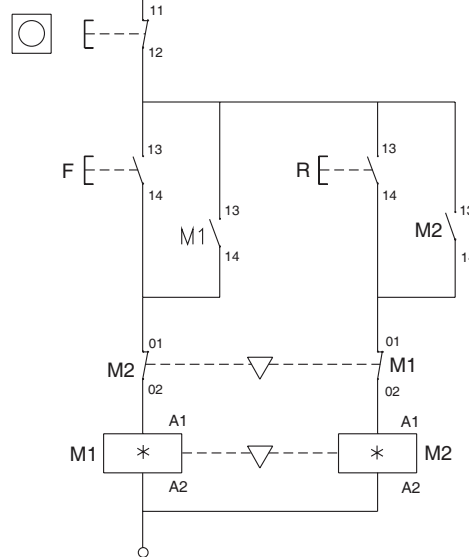

- M1 = Forward Contactor
- F = Forward Push Button
- M2 = Reverse Contactor
- R = Reverse Push Button
- E = Emergency Stop Push Button
- * = Coil Voltage Code

ELECTRICAL LIFE IN UTILIZATION CATEGORY

To find a contactor's estimated life:

1. Identify the utilization category of the application.
2. Refer to the chart for the applicable utilization category.
3. Locate the intersection of the life-load curve for the contactor selected with the application breaking current (Ie) on the horizontal axis of the chart.
4. Read the estimated contactor life from the vertical axis of the chart.

The life-load curves are based on tests in accordance with IEC 60947-4-1. Many conditions of an actual application effect contact life such as the environment and duty cycle. Therefore, the actual contact life may vary from the life indicated by the curves shown here.

NOTE: **Represents the Non-Reversing or Reversing Contactor Code. Refer to Pages 6 & 8.

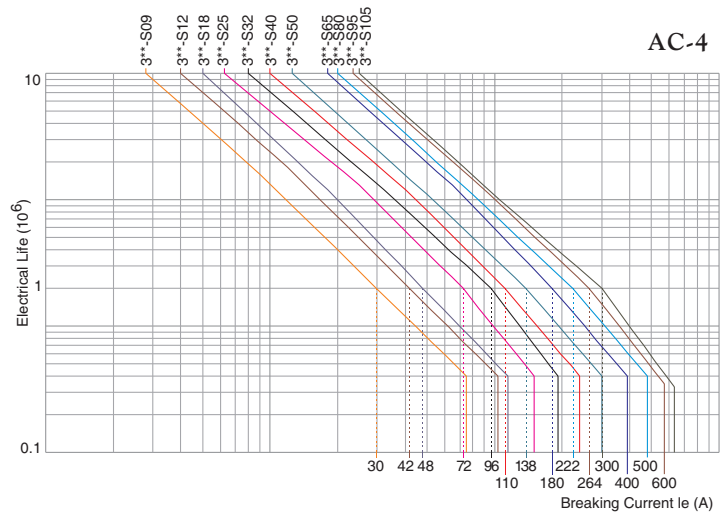
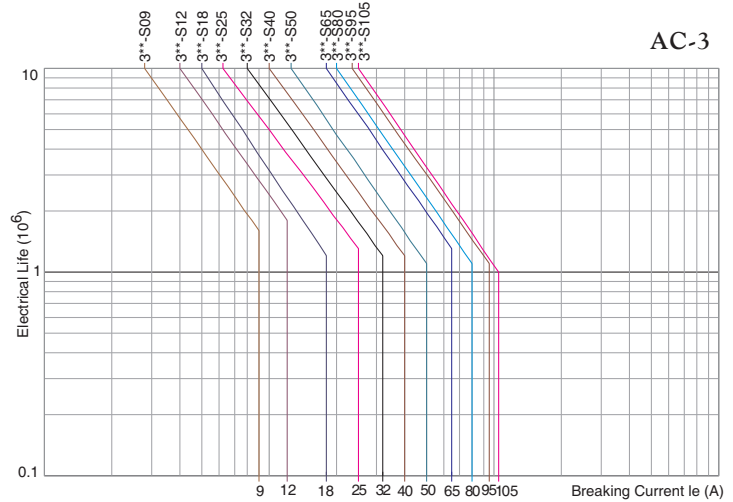
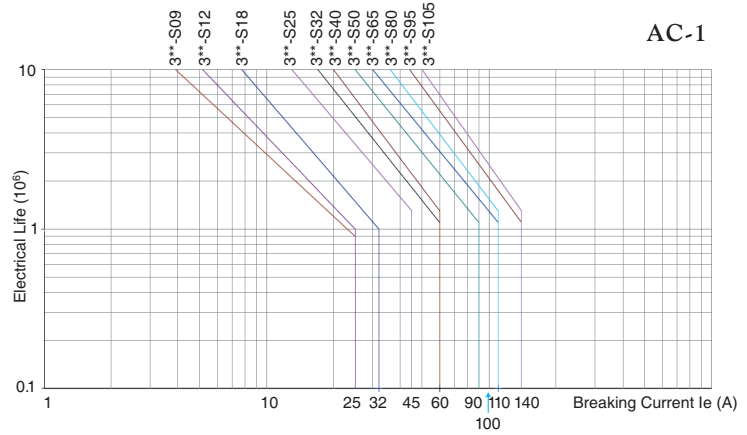

3 POLE NON-REVERSING CONTACTORS - AC COILS

300-S09, 300-S12, 300-S18 & 300-S25

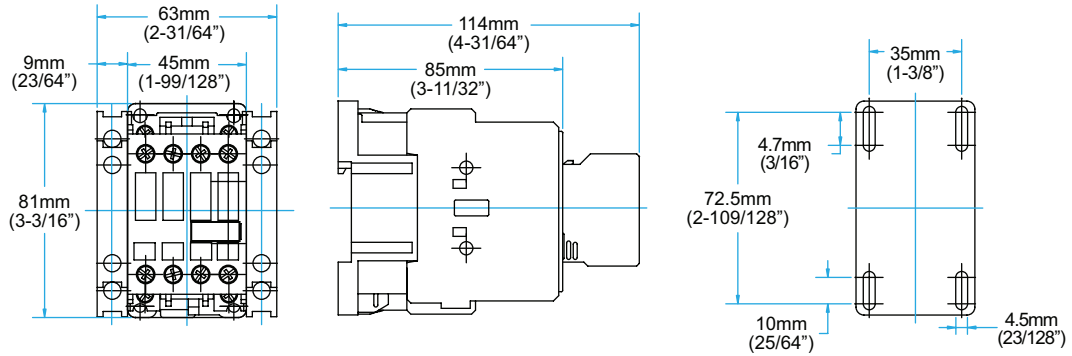

300-S32 & 300-S40

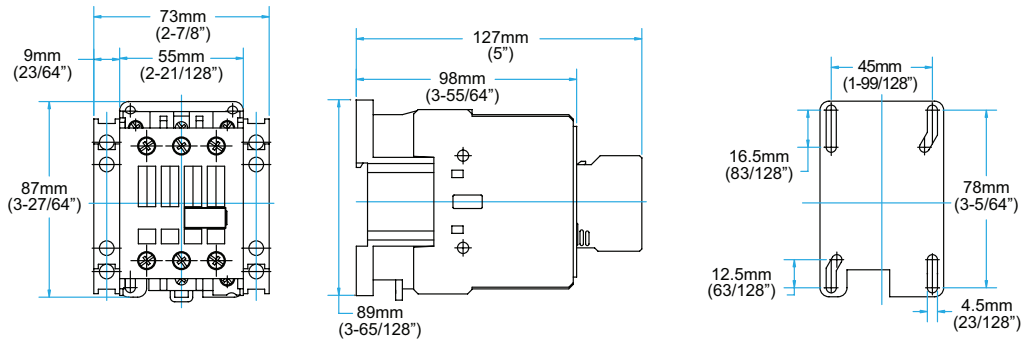

300-S50, 300-S65 & 300-S80

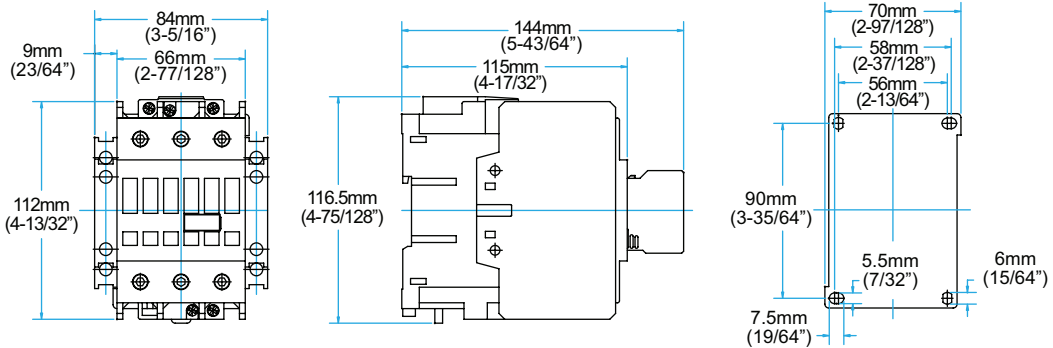

300-S95 & 300-S105

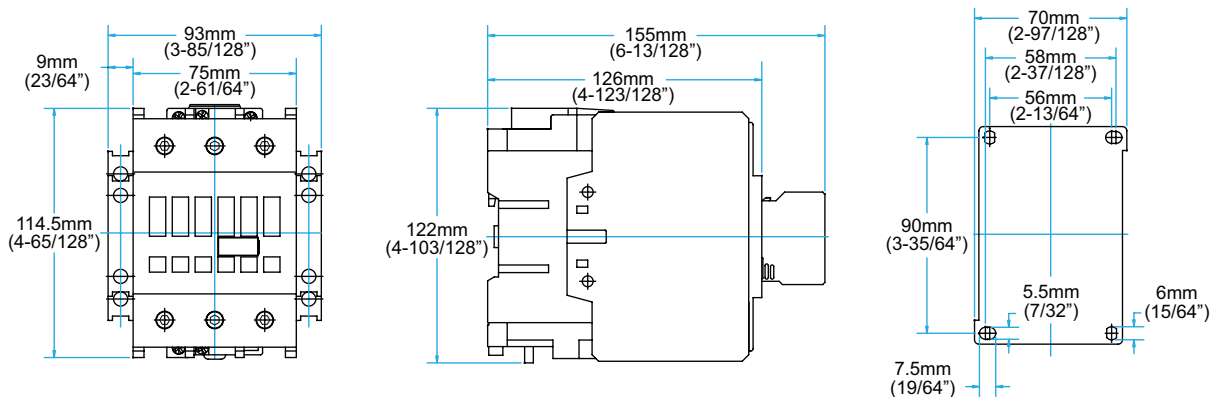

3 POLE NON-REVERSING CONTACTORS - DC COILS

300-S09, 300-S12, 300-S18 & 300-S25

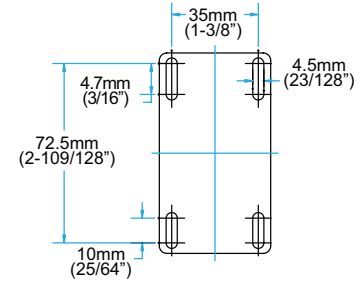
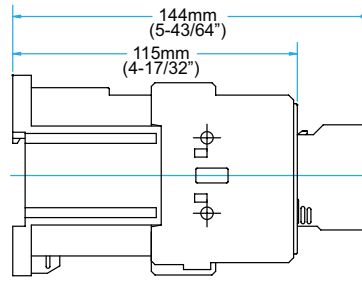
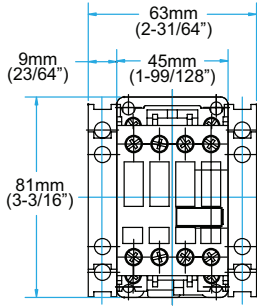

300-S32 & 300-S40

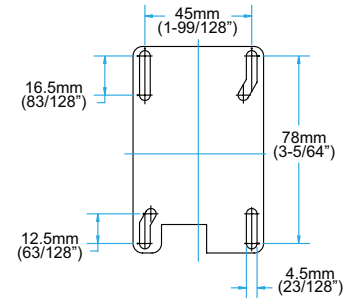
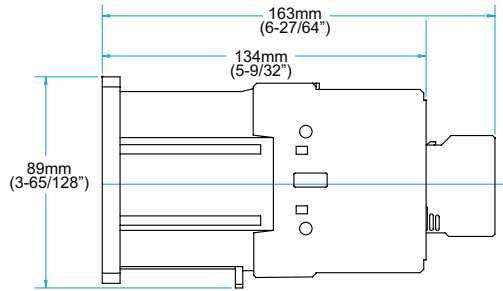
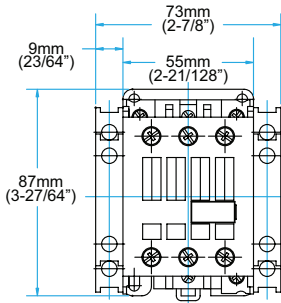

300-S50, 300-S65 & 300-S80

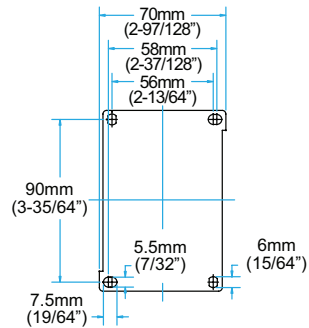
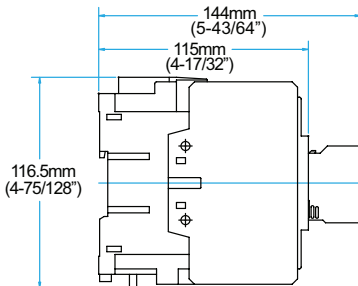
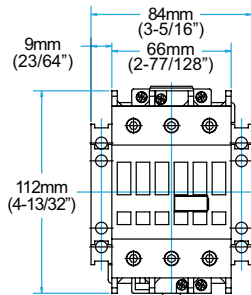

300-S95 & 300-S105

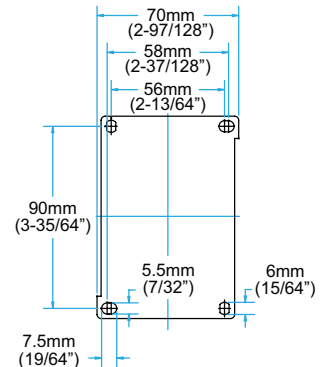
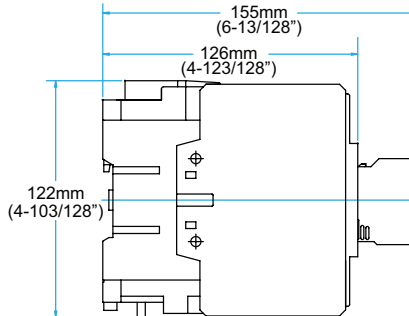
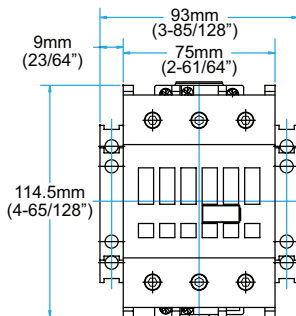

3 POLE CONTACTORS WITH ELECTRICAL / MECHANICAL OR MECHANICAL INTERLOCK - AC COILS

310-S09, 310-S12, 310-S18 & 310-S25

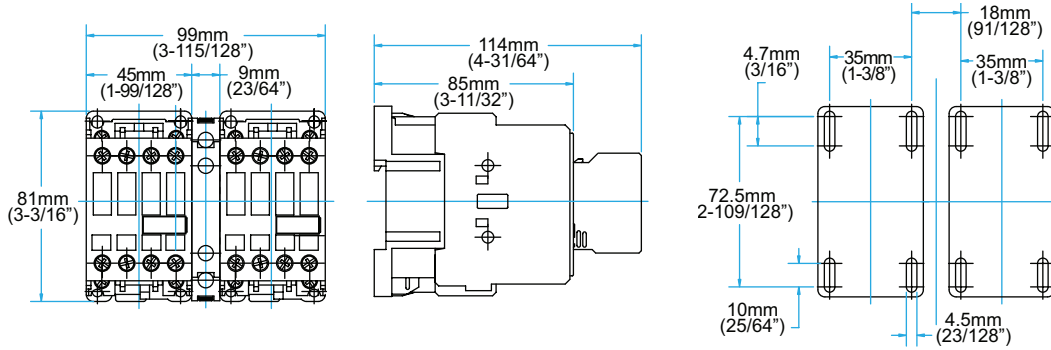

310-S32 & 310-S40

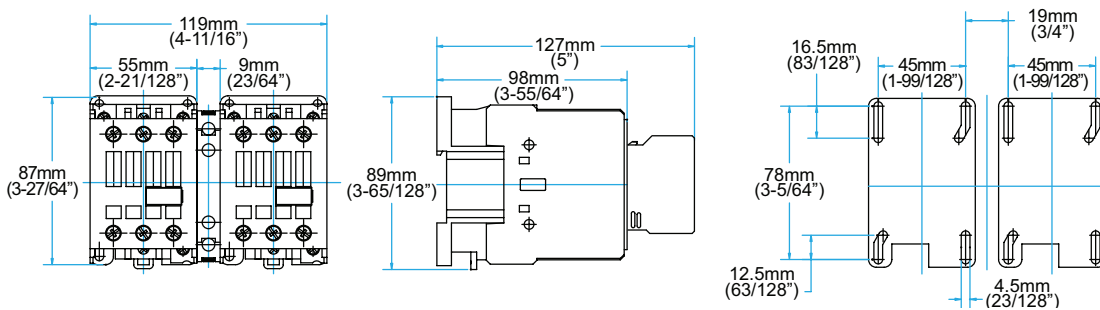

310-S50, 310-S65 & 310-S80

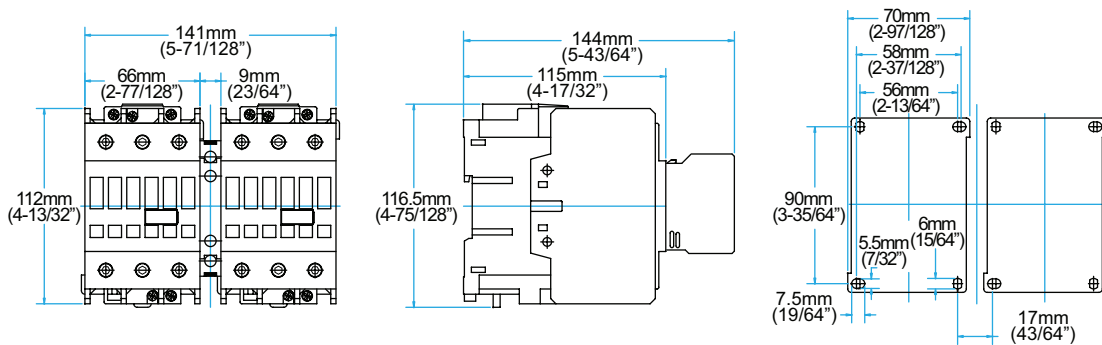

310-S95 & 310-S105

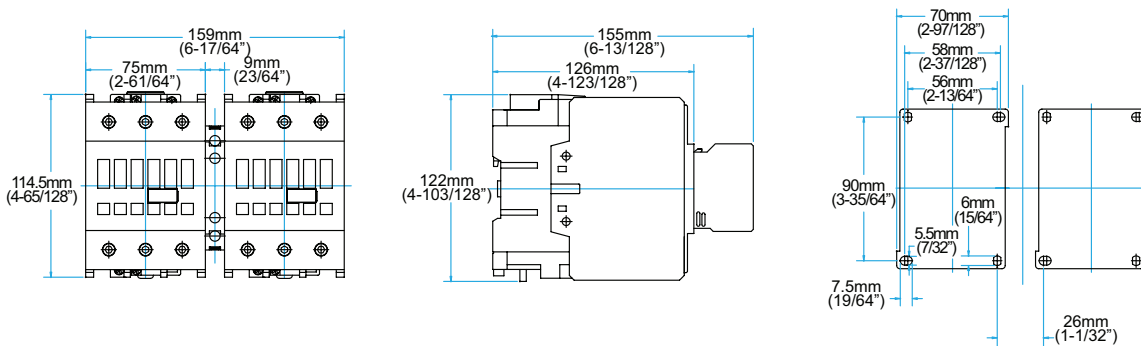

3 POLE CONTACTORS WITH ELECTRICAL/MECHANICAL OR MECHANICAL INTERLOCK - DC COILS

310-S09, 310-S12, 310-S18 & 310-S25

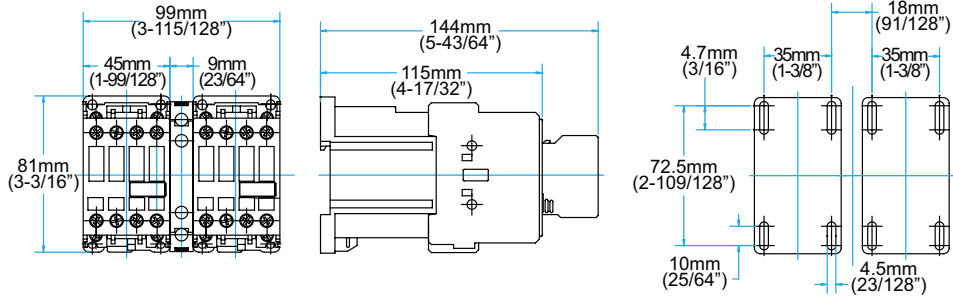

310-S32 & 310-S40

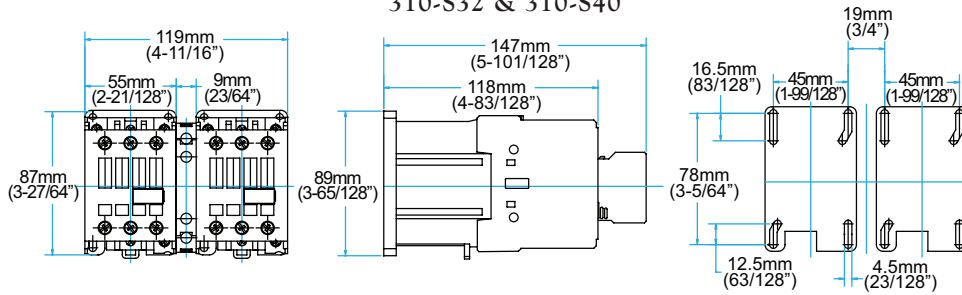

310-S50, 310-S65 & 310-S80

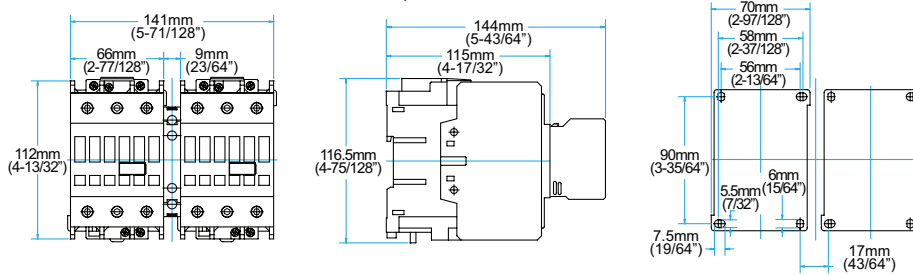

310-S95 & 310-S105

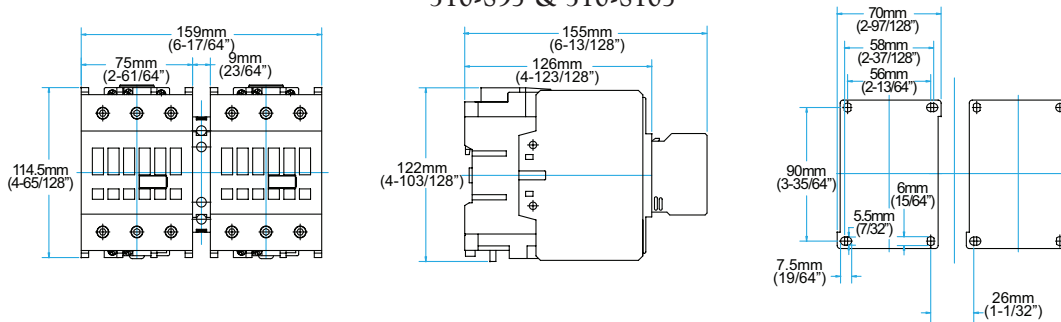

**VISIT WWW.C3CONTROLS.COM
TO DOWNLOAD CAD DRAWINGS**